

К. П. Некрасовъ,
инженеръ Путей Сообщенія.

Обыкновенныя дороги.

Часть III.

Городскія мостовыя

и

тротуары.

Атласъ.

МОСКВА.
1913 г.

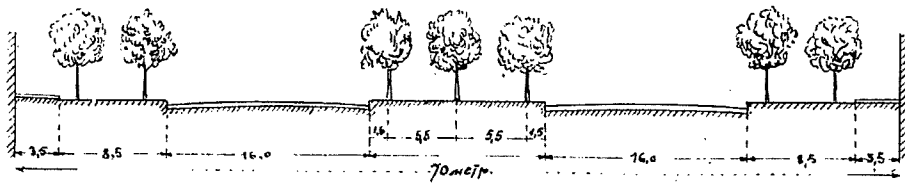

1

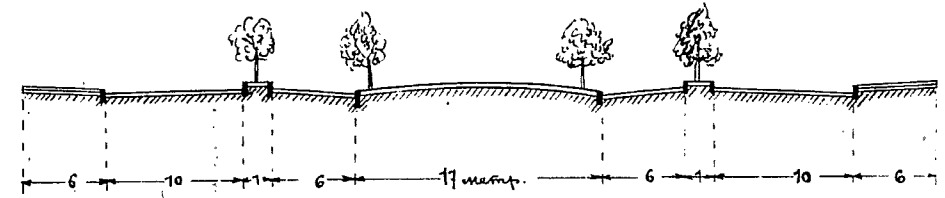

2

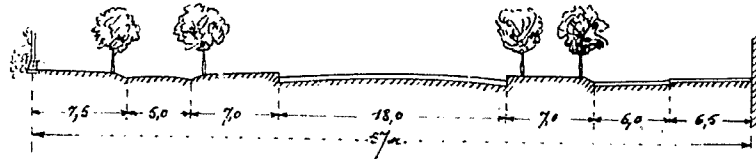

3

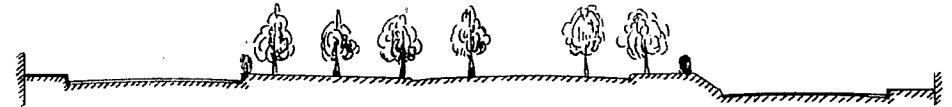

4

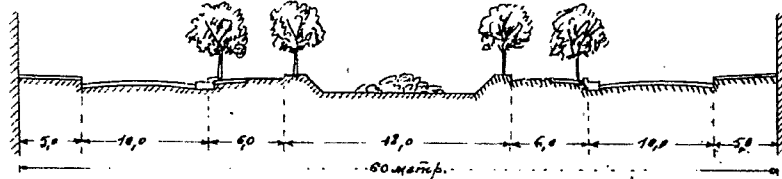

5

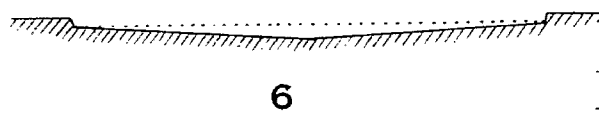

6

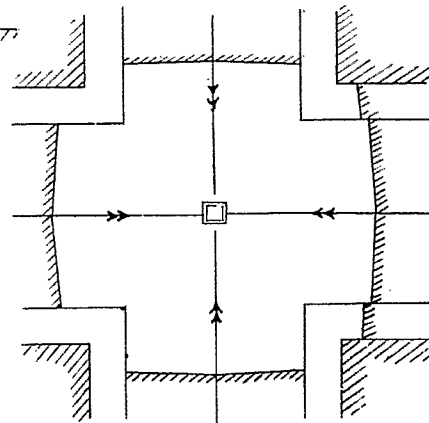

7

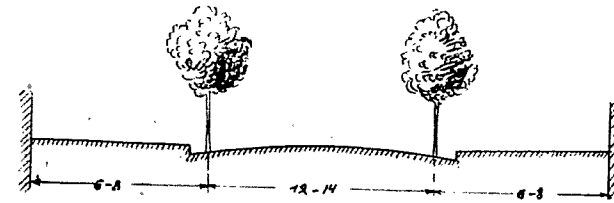

9

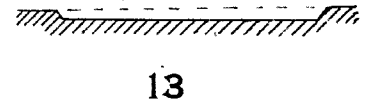

13

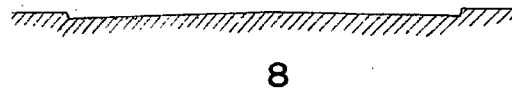

8

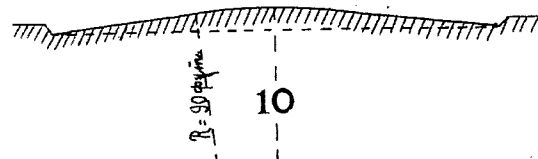

10



12

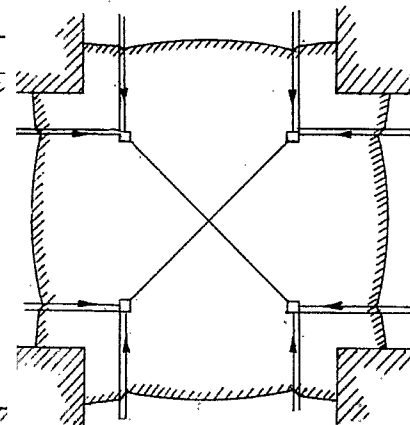

11

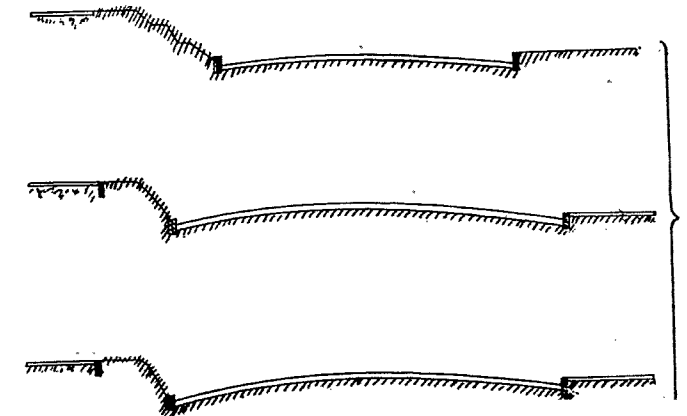

14

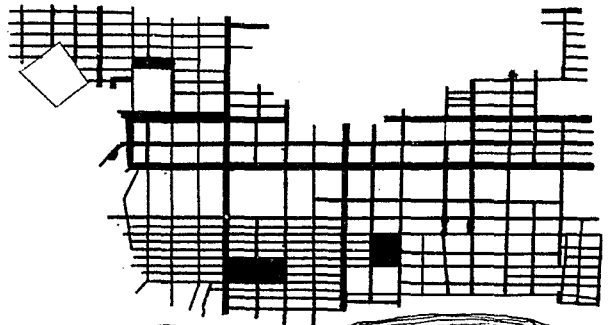

Планъ г. Постова на Дону.

15 а

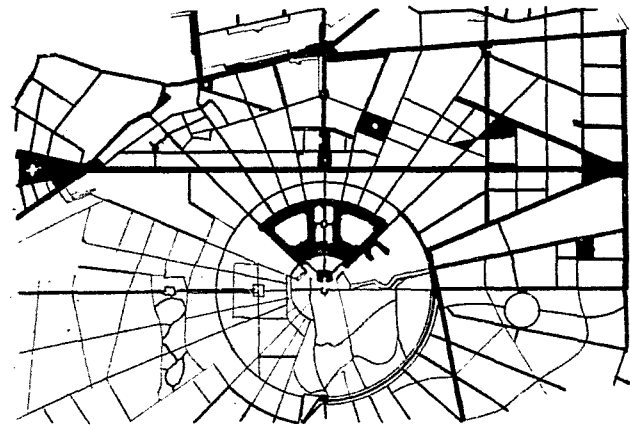

15 в

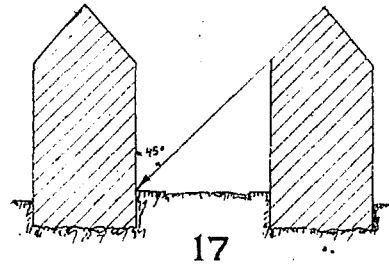

17

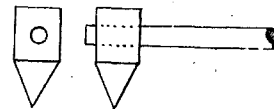

18

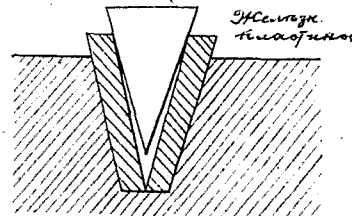

19

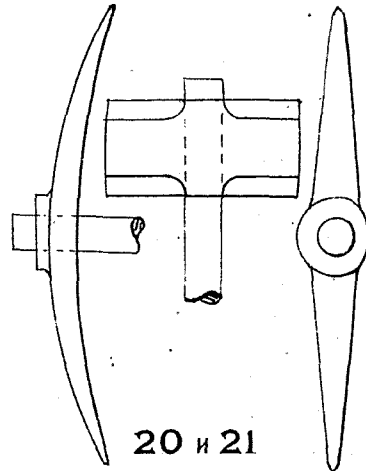

20 и 21

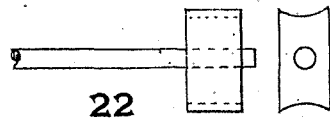

22

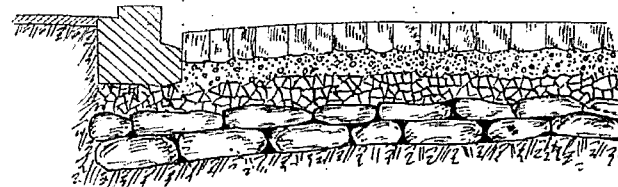

23

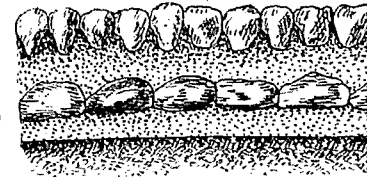

25

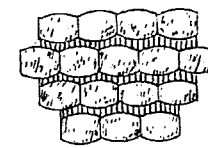

26

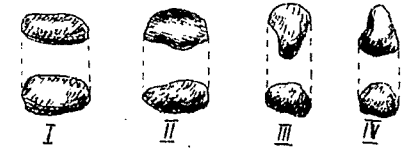

24

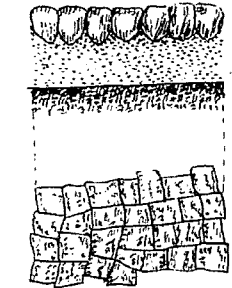

27

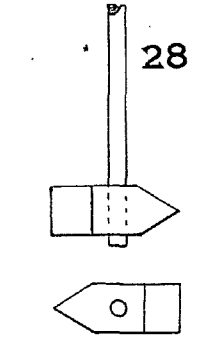

28



29

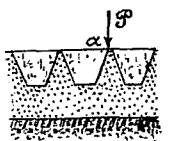

33

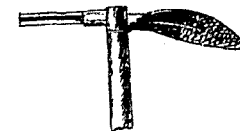

30



α

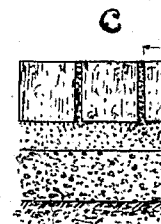
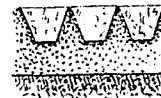

32



31

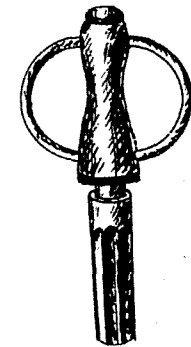

34

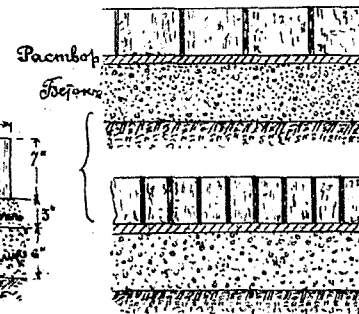
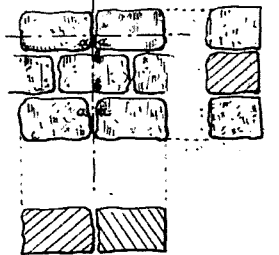

35

16

Планъ части гора Антверпена.

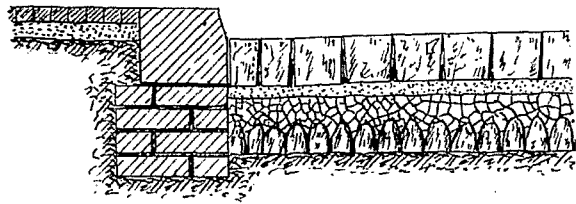

36

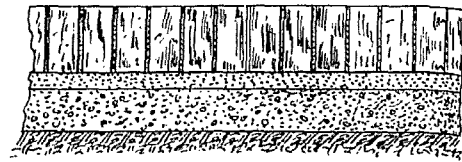

37

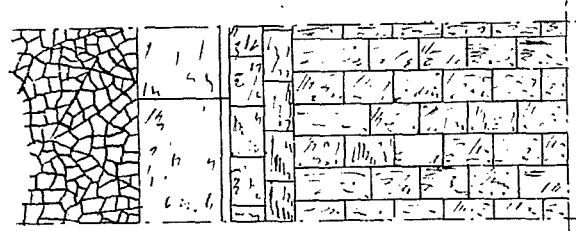

38

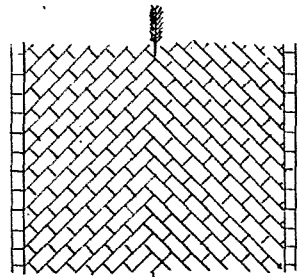

39

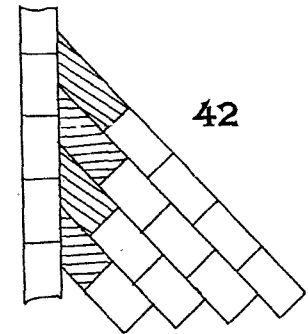

42

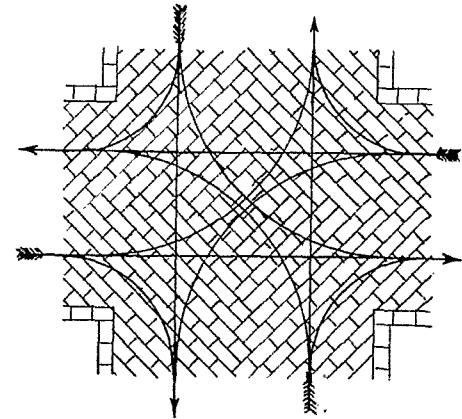

40

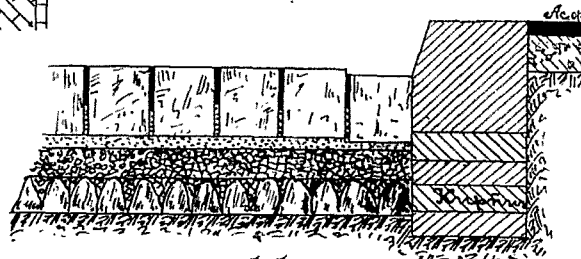

44



45

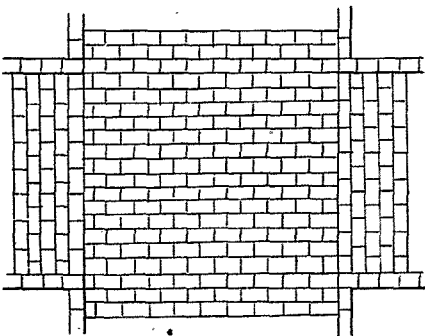

41

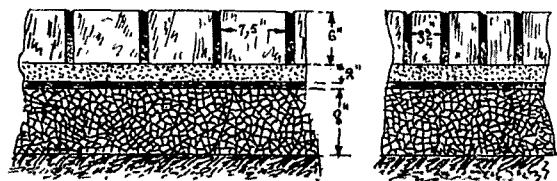

48

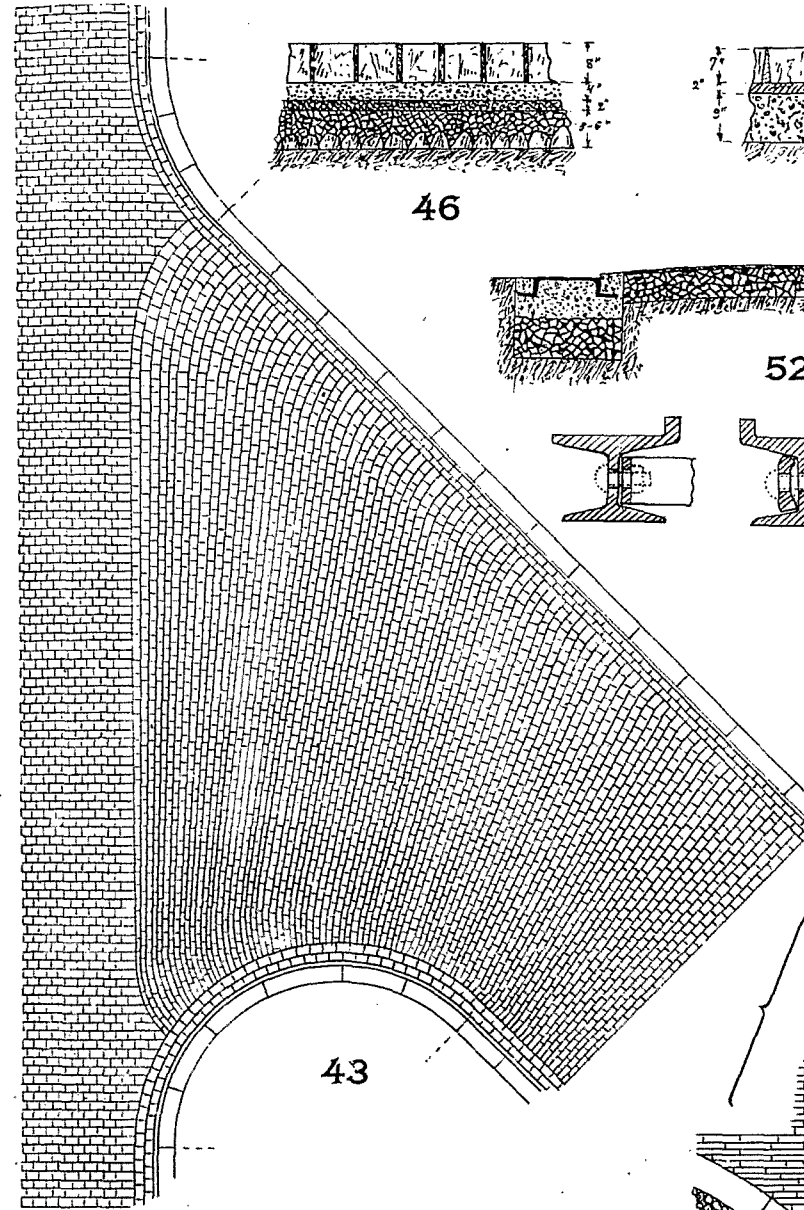

43

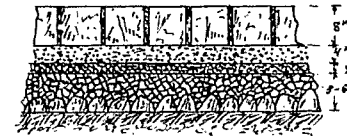

46

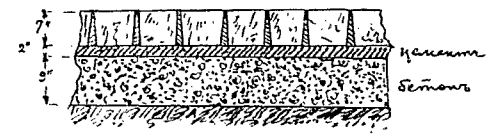

47

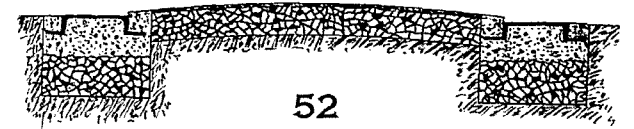

52

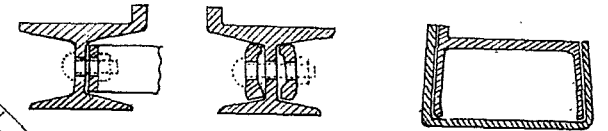

53

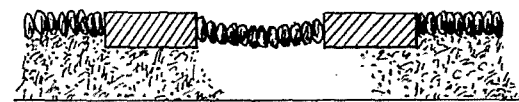

49

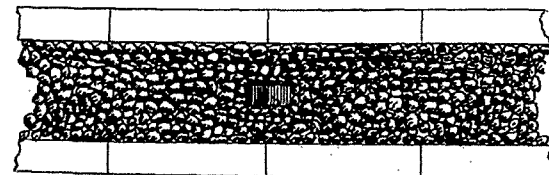

50

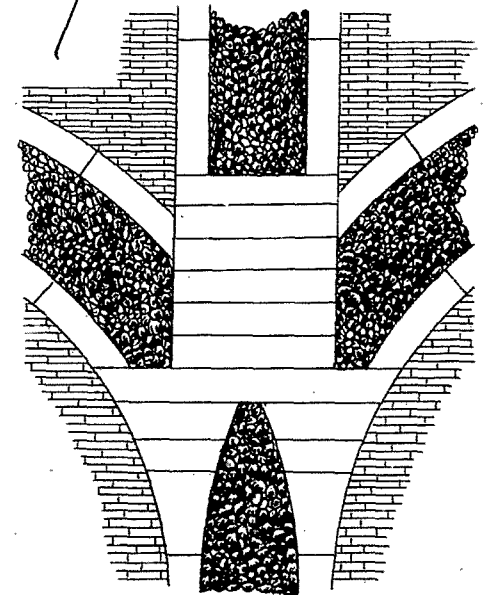

51

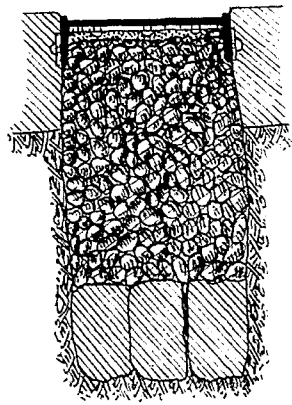

54



55

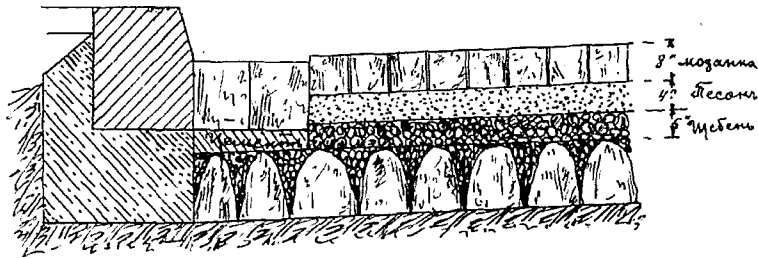

57

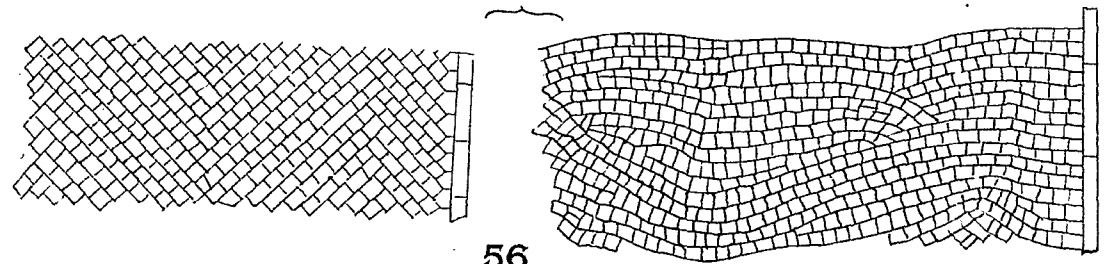

56

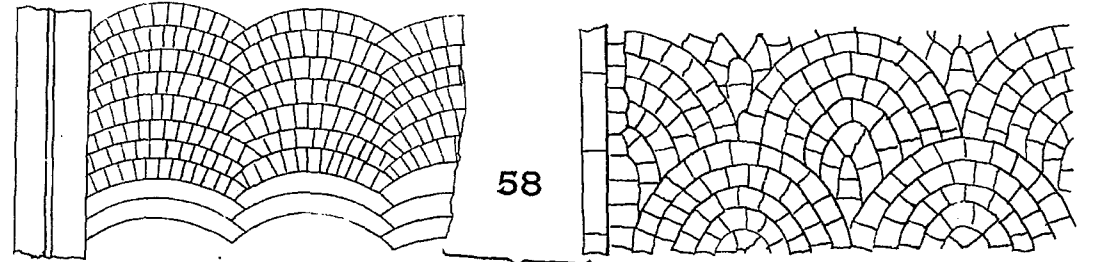

58

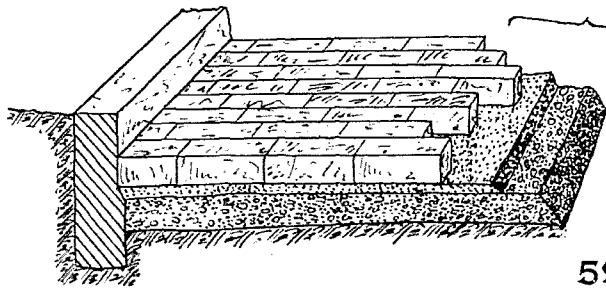

59

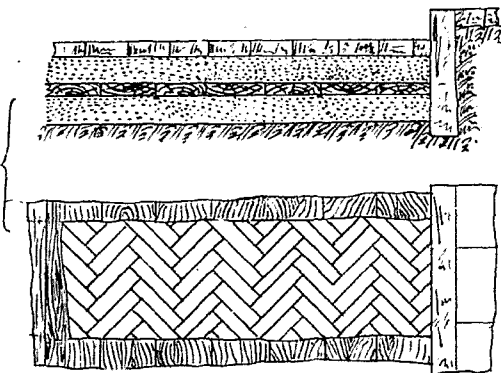
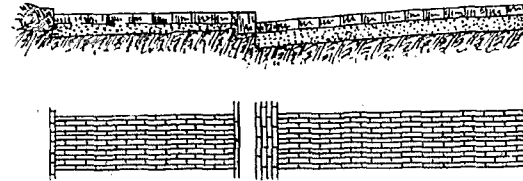

61

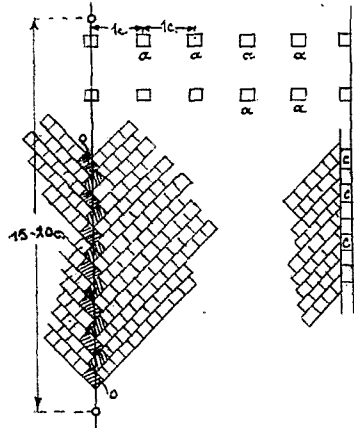

62



63

65

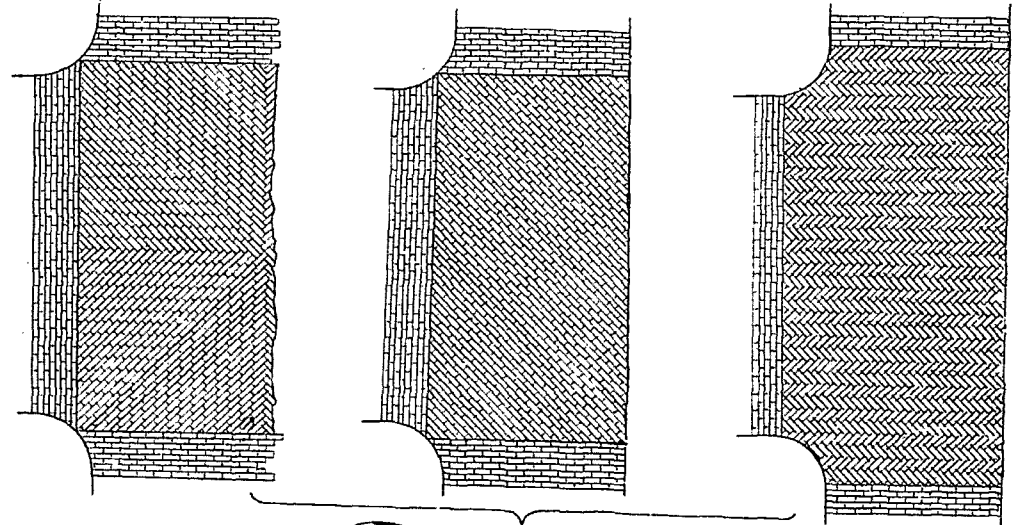

60

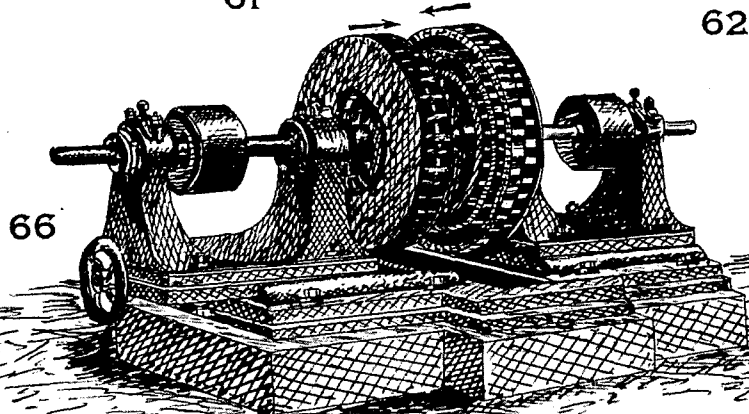

66

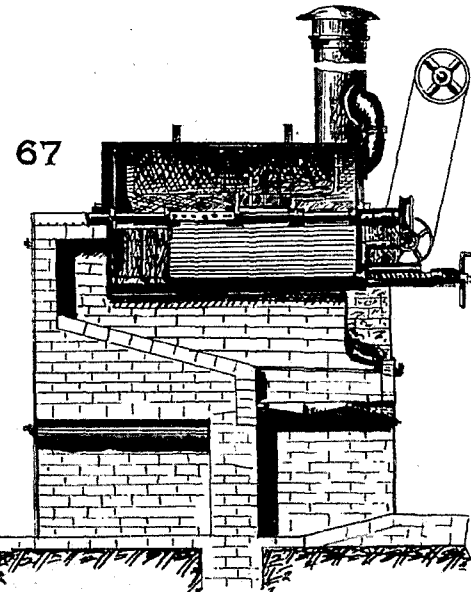

67

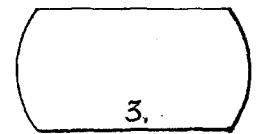

3.

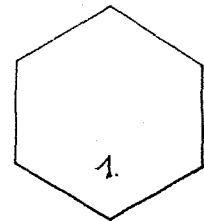

1.

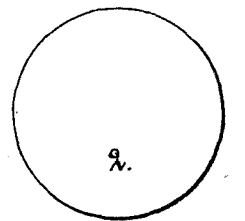

2.

68

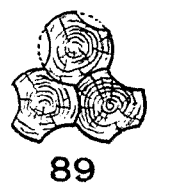
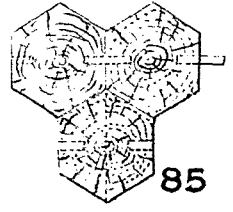
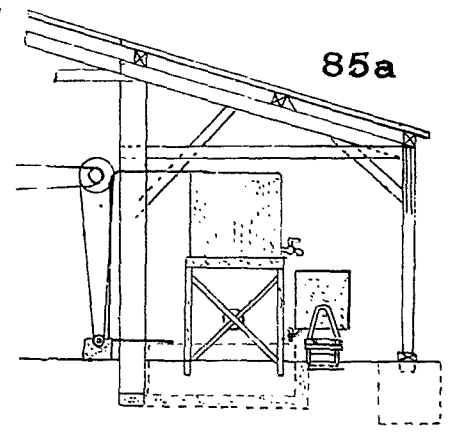
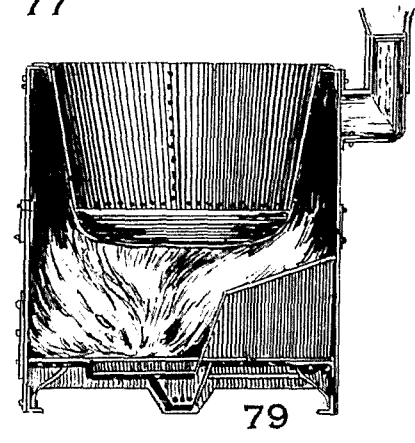
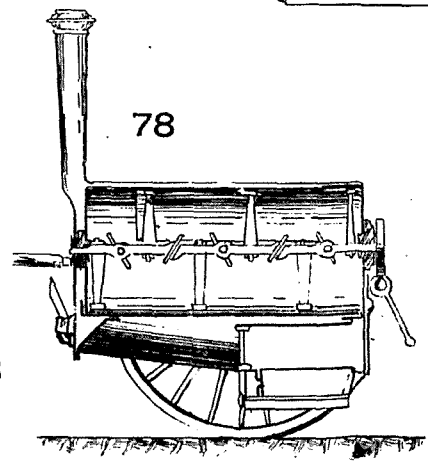
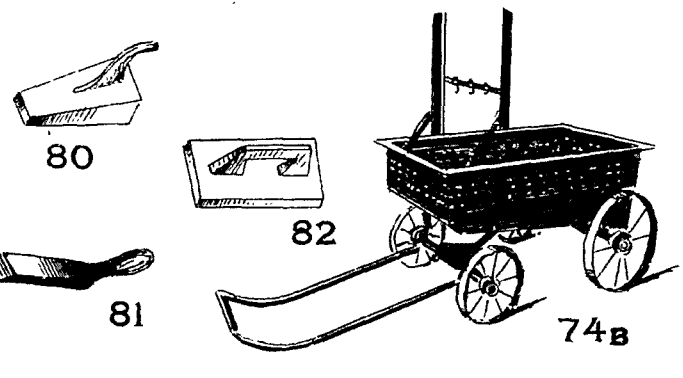
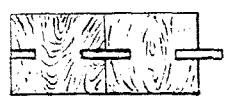
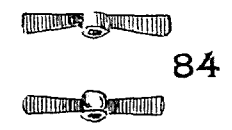
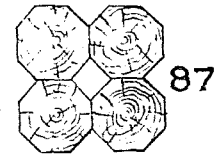
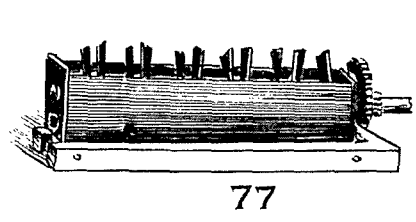
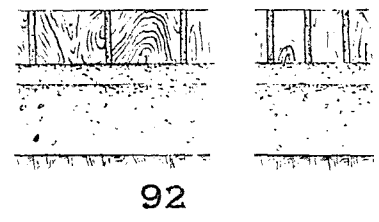
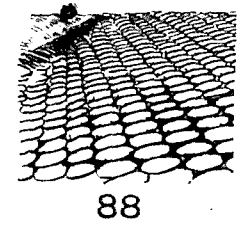
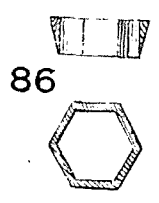
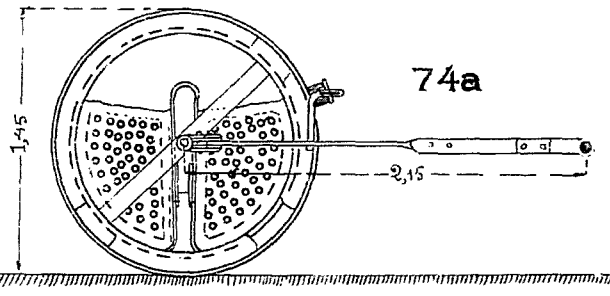
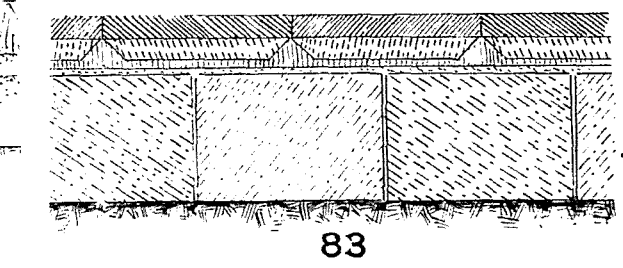
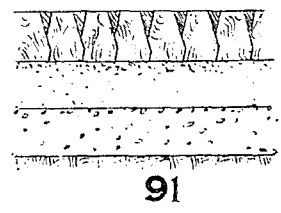
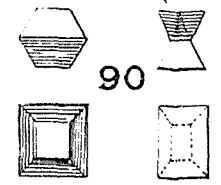
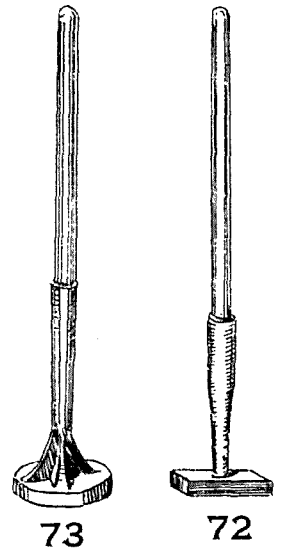
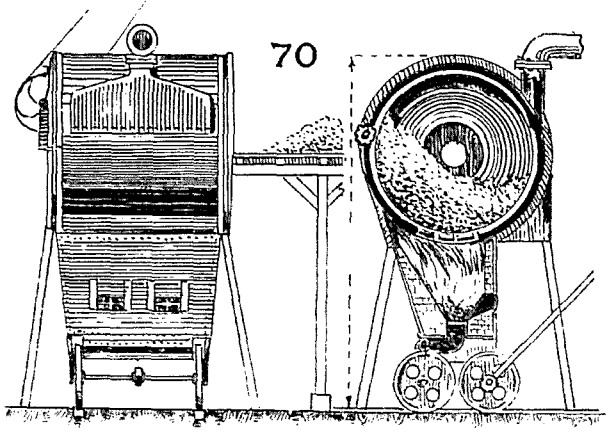
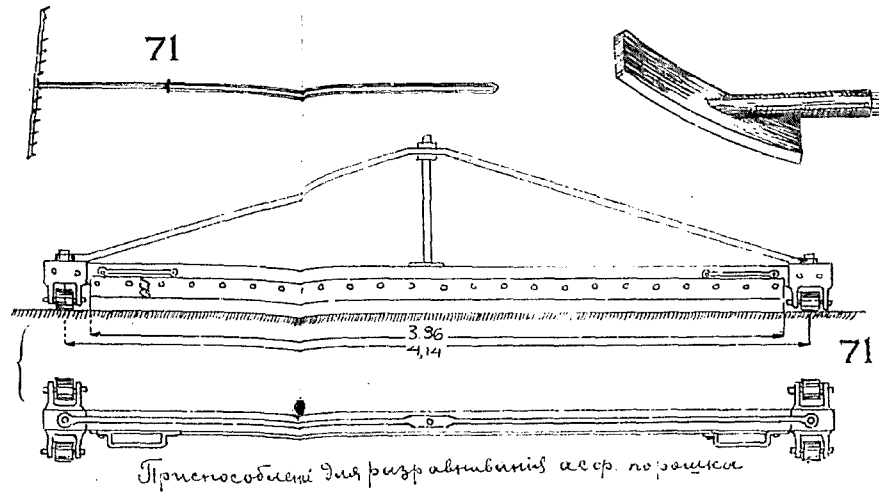
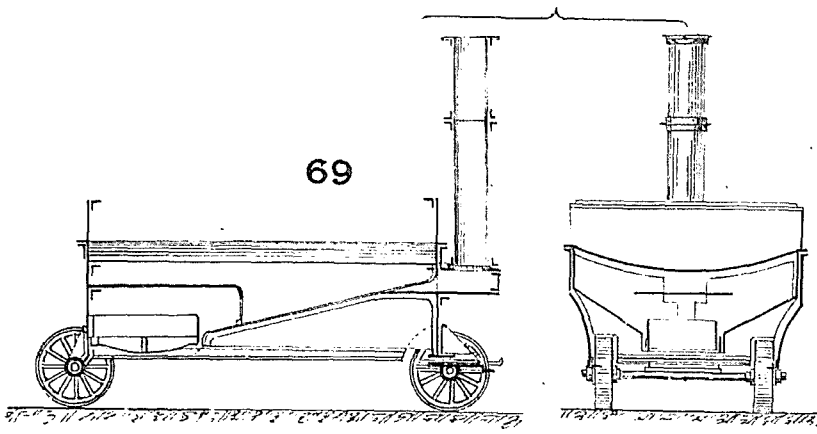

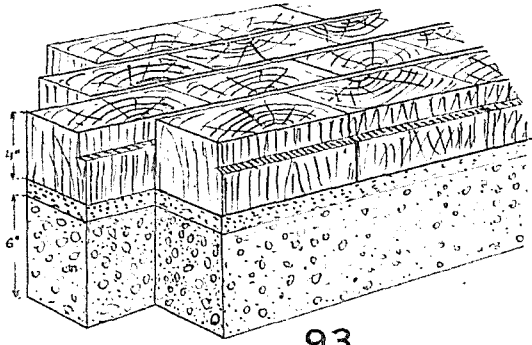

93

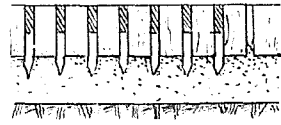

94

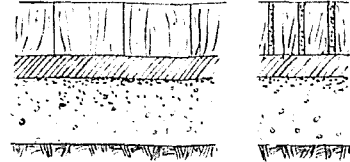

96

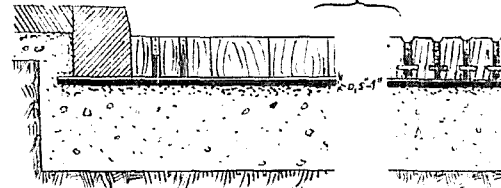

97

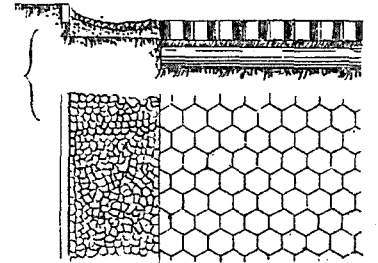

100

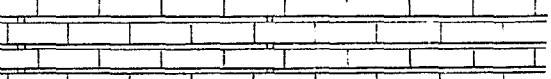
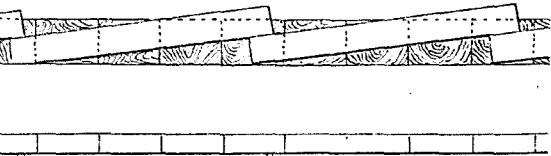

102

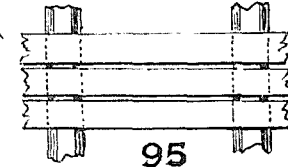
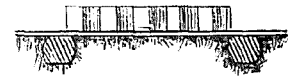

95

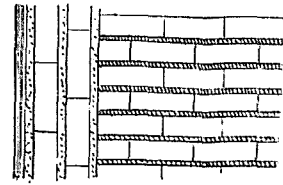
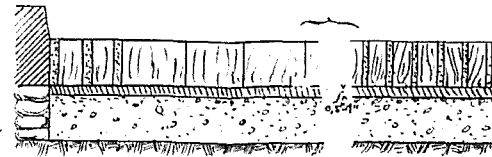

98



99

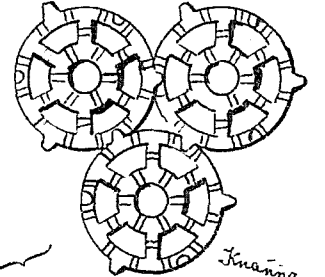
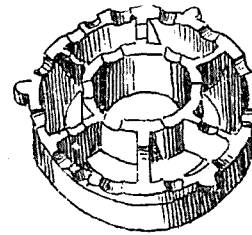

104

Knapp

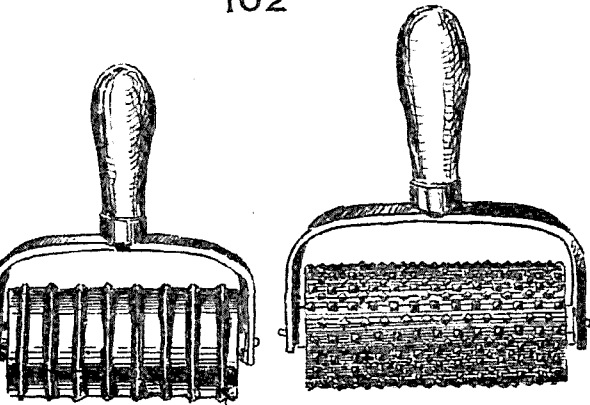

113

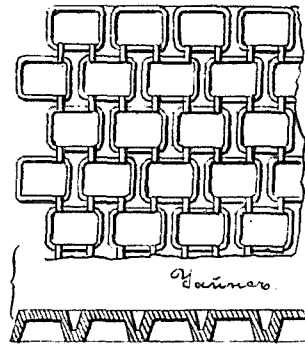

103

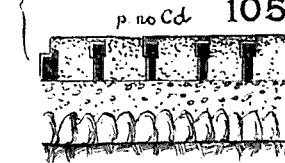
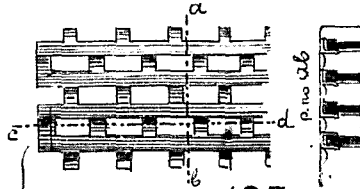

105

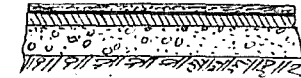

106

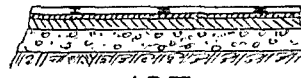

107

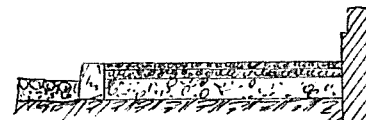

108

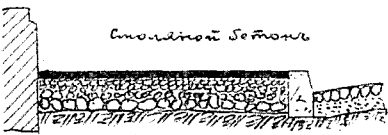

114

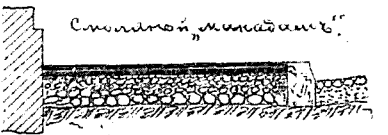
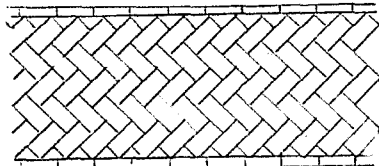

115

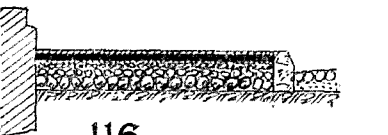
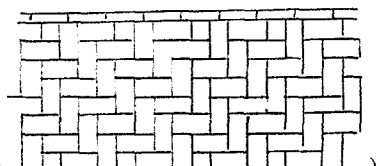

116

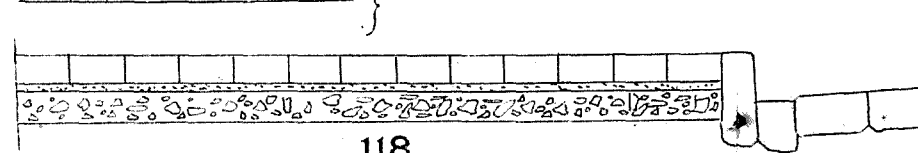

118



110

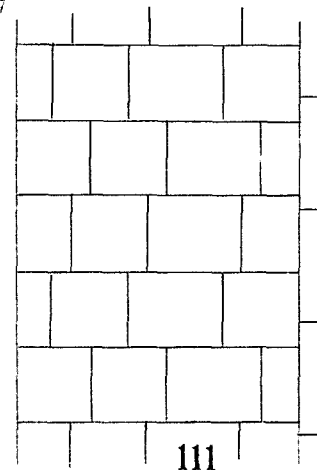

111

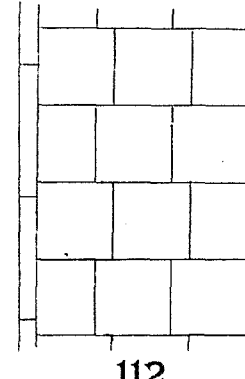

112

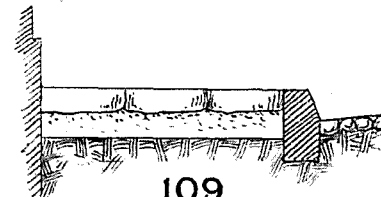

109

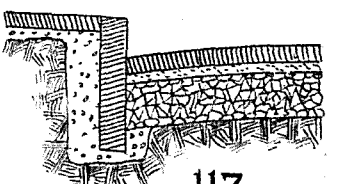
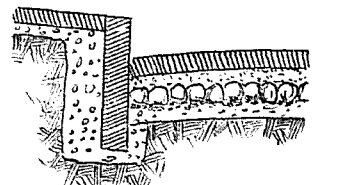
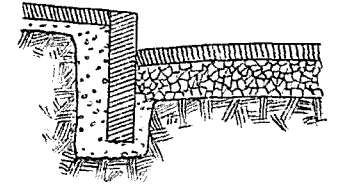
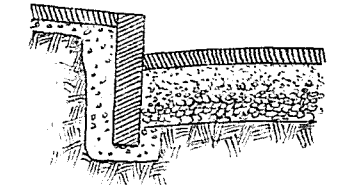

117

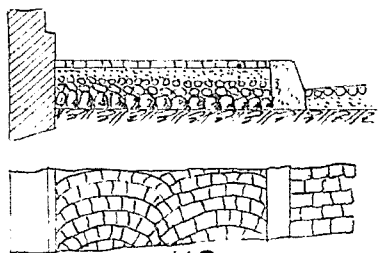

119

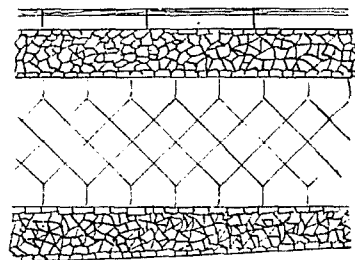

120

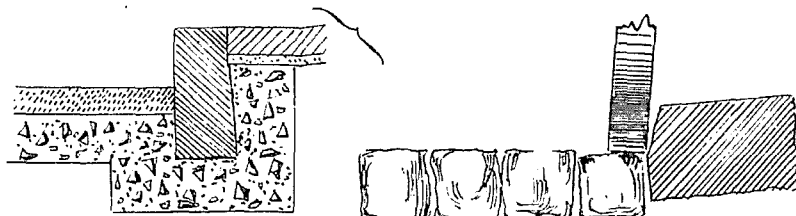

121

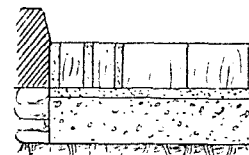

125

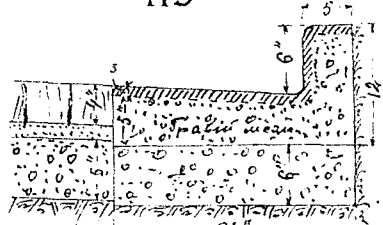

123

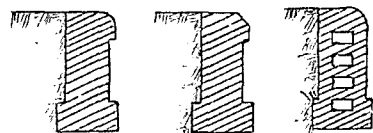

122

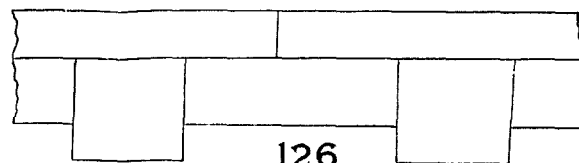

126

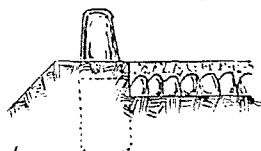

128

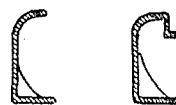
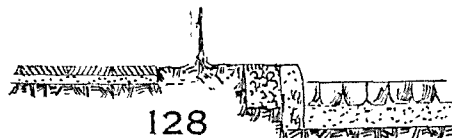

124



129

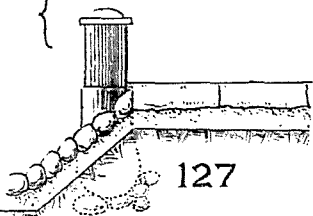

127



130

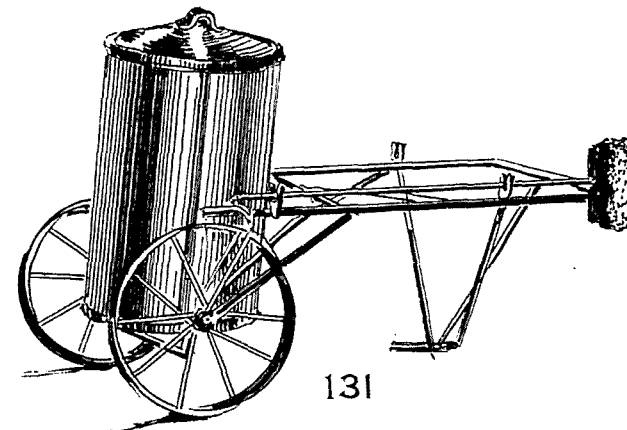
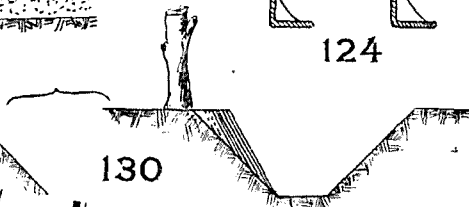

131

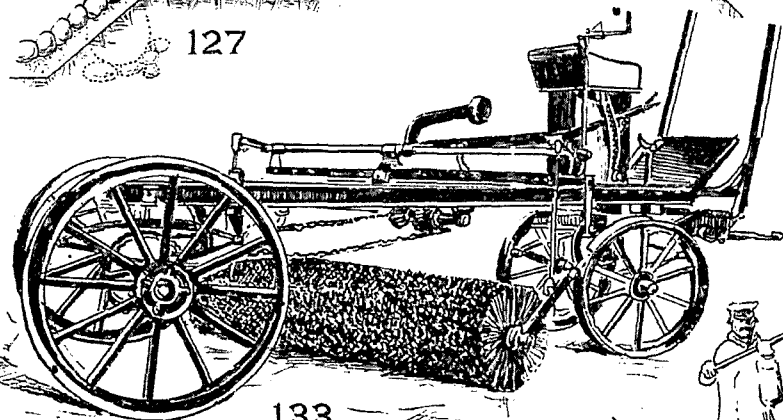

133

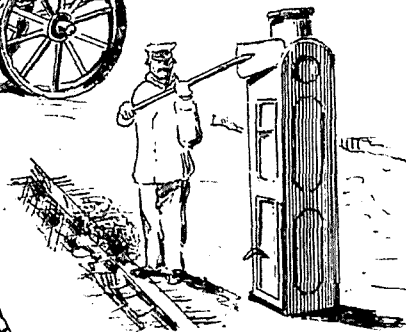

132

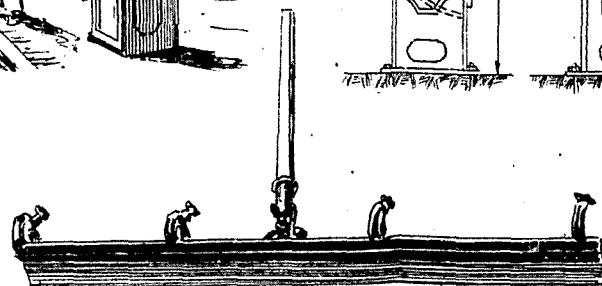
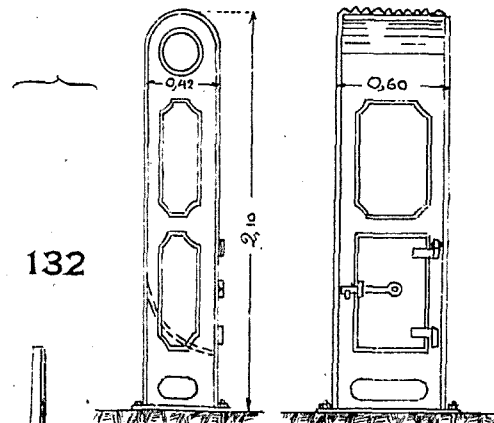

135

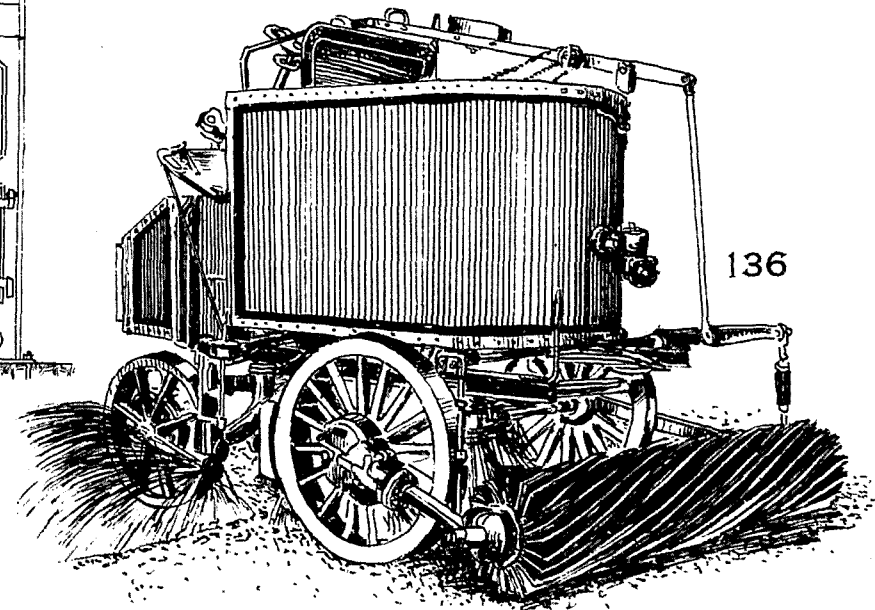

136

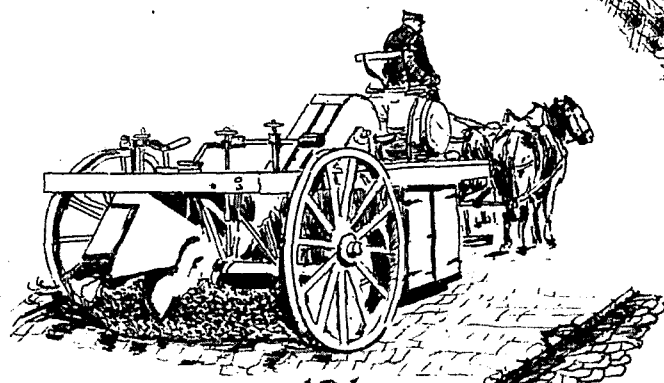

134

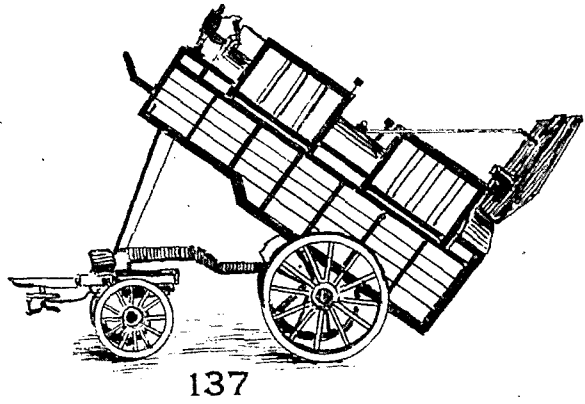

137

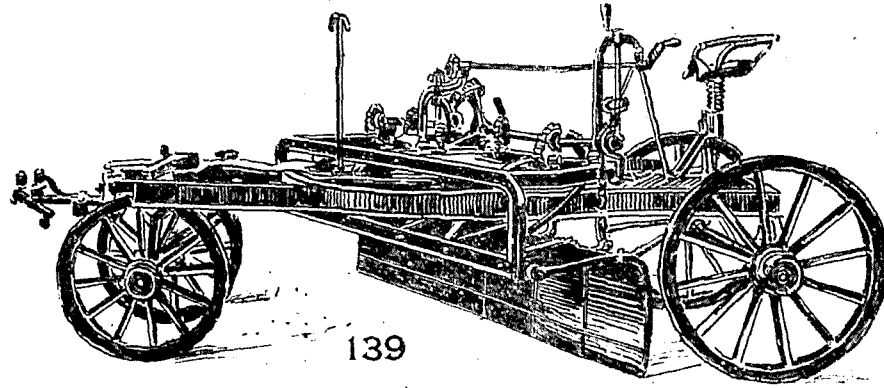

139

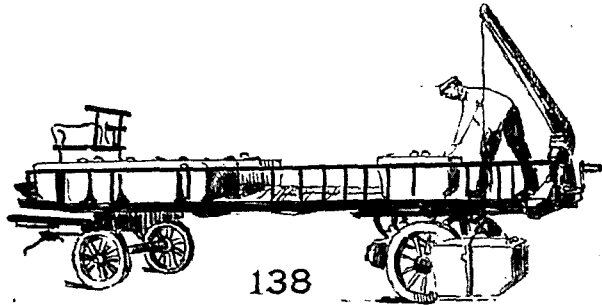

138

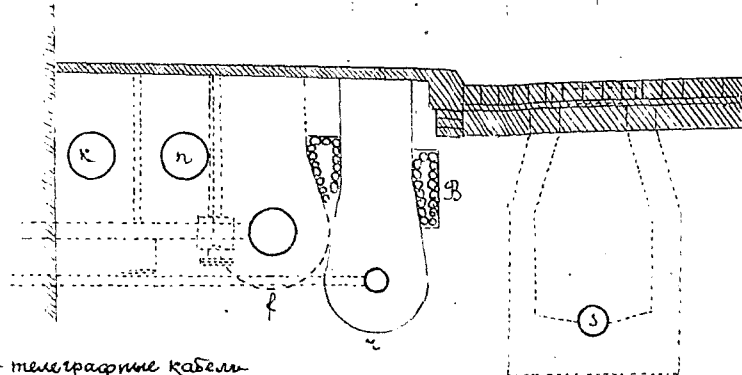

к - телеграфные кабели
 п - телефонные
 т - трамвайные

141

г - газопровод
 в - водопровод
 с - канализация

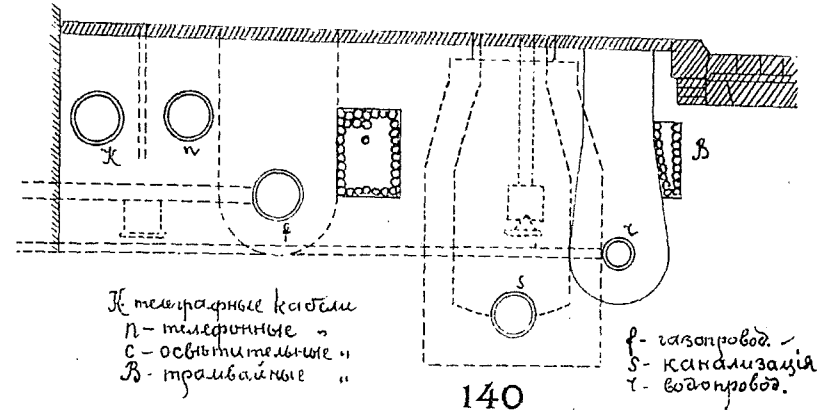

к - телеграфные кабели
 п - телефонные
 с - осветительные
 т - трамвайные

140

г - газопровод
 с - канализация
 т - водопровод.

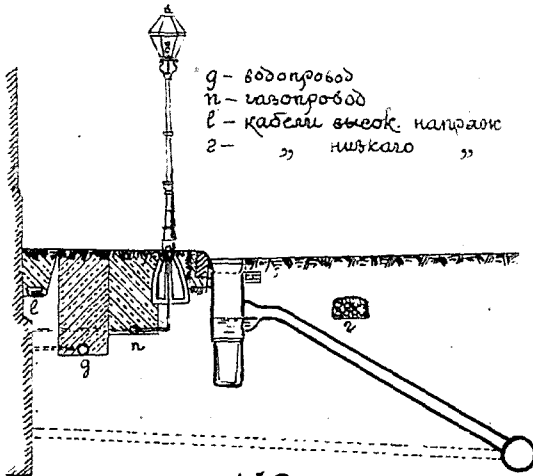

г - водопровод
 п - газопровод
 в - кабели высокого напряжения
 т - " низкого "

142

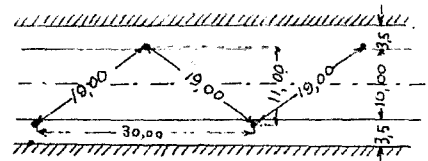

145

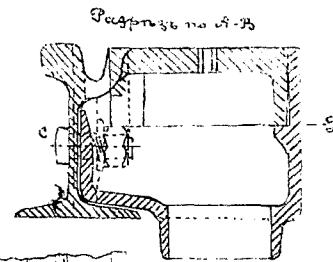

143

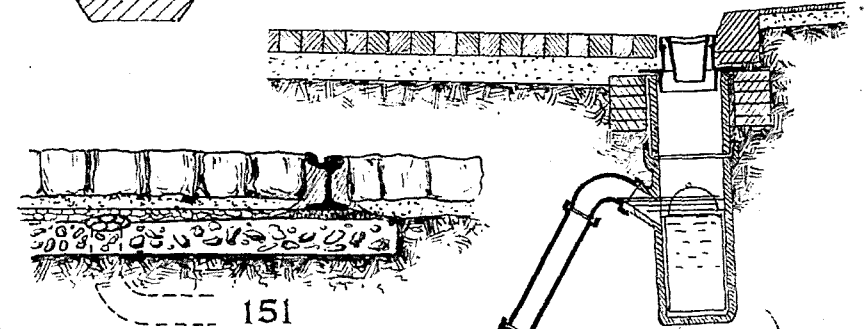

144

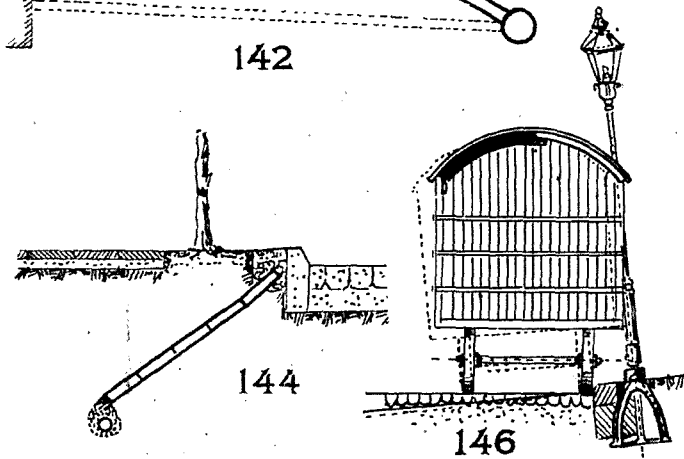

146

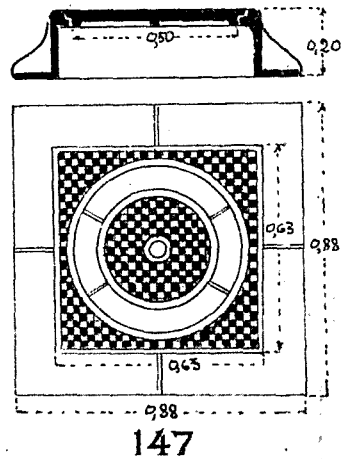

147

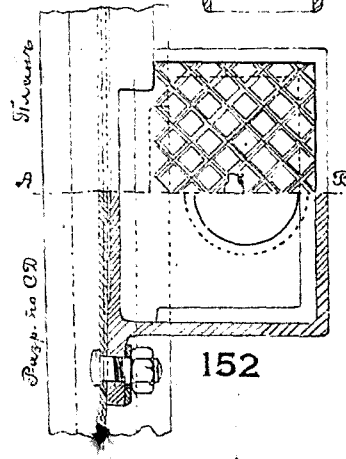

148

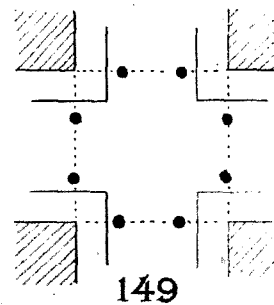

149

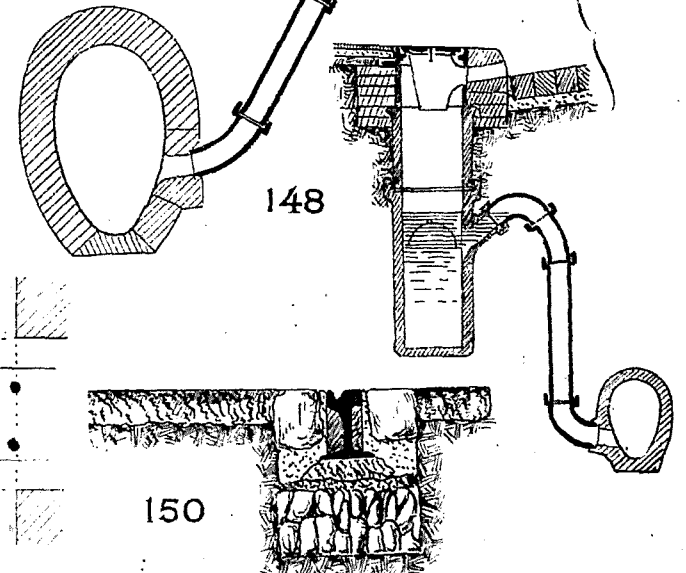

150

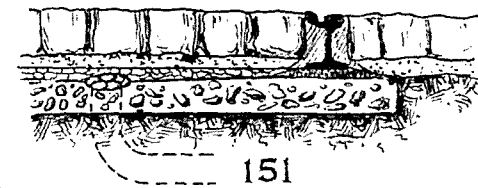

151

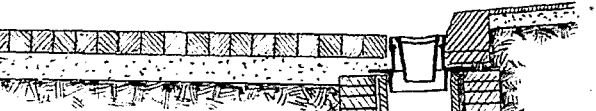

152

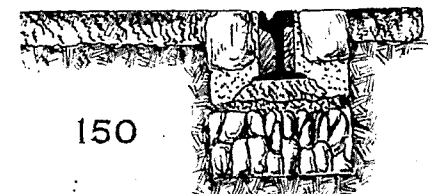

153